



# Binks Model M1-G HVLP GRAVITY FEED SPRAY GUN

The Binks M1-G HVLP Gravity Feed Gun is a high quality sprayer that produces fine finish for compliant and non-compliant areas. A superbly balanced forged aluminum body provides you with extra comfort and control. All components are machined and finished to exacting tolerances and only the best materials are used, ensuring years of peak efficiency.

Simple to operate, the M1-G HVLP provides exceptional finishes with complex coatings such as primers, base coats, clear coats, single stage and waterborne compliant materials. Additionally, specially designed air and fluid nozzles enable the M1-G HVLP to operate at more than 65% transfer efficiency, in compliance with air quality regulations as a high volume low pressure air spray gun.

The Binks M1-G HVLP Gravity Feed Spray Gun includes a metal paint cup with drip-proof cover.

To obtain optimum performance from your new M1-G HVLP Gravity Feed Spray Gun, read all instructions carefully.

**NOTE**

IMPORTANT REGULATORY NOTE regarding the use of this product appears on page 9.

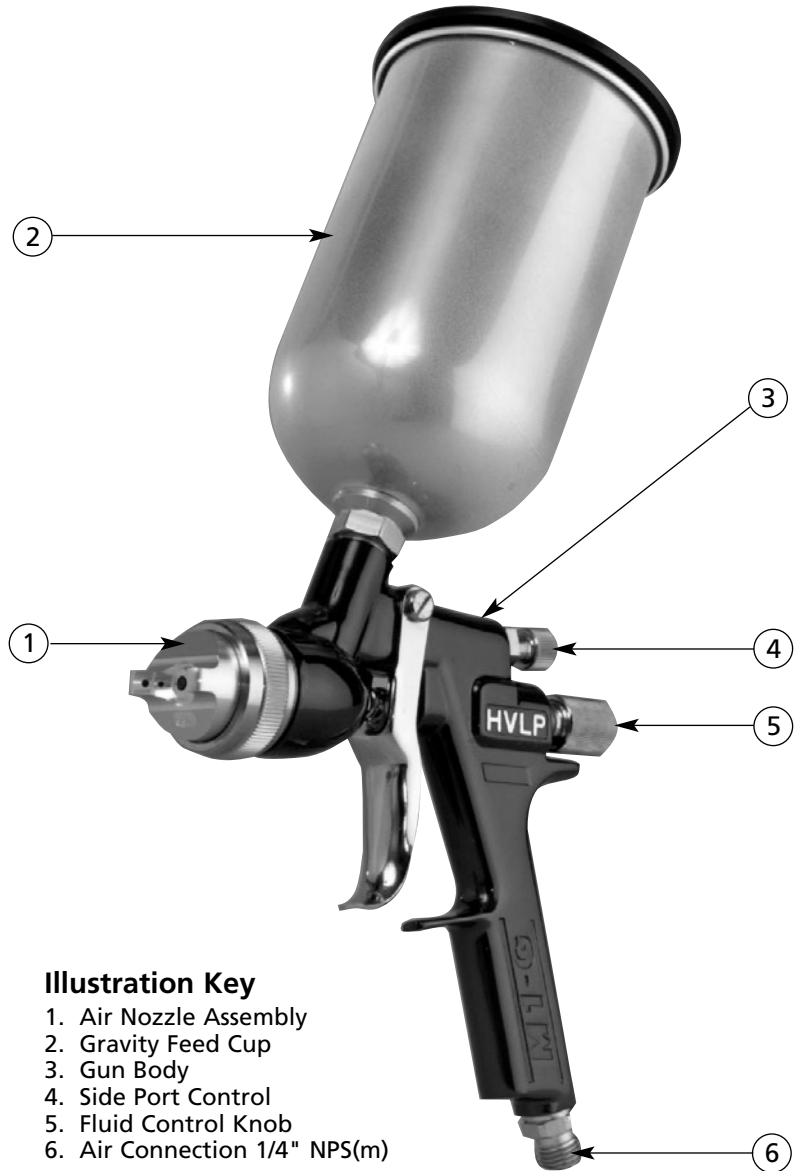

### Illustration Key

1. Air Nozzle Assembly
2. Gravity Feed Cup
3. Gun Body
4. Side Port Control
5. Fluid Control Knob
6. Air Connection 1/4" NPS(m)

### PACKAGE CONTENTS

Please note your Binks M1-G HVLP Gravity Feed Spray Gun package was shipped with the following contents. If anything in the following list is missing, call 1-800-992-4657 for a prompt shipment to you of the missing item.

PART NO.	DESCRIPTION	QTY.
	M1-G HVLP GRAVITY FEED SPRAY GUN .....	1
77-2650	M1-G PART SHEET .....	1
54-4720	1 LITER GRAVITY FEED CUP ASSEMBLY .....	1
SBBI-4-043	1 LITER CUP ASSEMBLY PART SHEET .....	1
54-3871	GUNNERS MATE .....	1
82-469	GUN BRUSH (ROUND) .....	1
192219	PLASTIC COATED GUN HOOK .....	1
82-221	CLEANING BRUSH (FLAT) .....	1

Replaces Part Sheet 77-2650R-6 | Part Sheet 77-2650R-7

In this part sheet, the words **WARNING**, **CAUTION** and **NOTE** are used to emphasize important safety information as follows:

**⚠ WARNING**  
 Hazards or unsafe practices which could result in severe personal injury, death or substantial property damage.

**⚠ CAUTION**  
 Hazards or unsafe practices which could result in minor personal injury, product or property damage.

**NOTE**  
 Important installation, operation or maintenance information.

**⚠ WARNING**

Read the following warnings before using this equipment.



**READ THE MANUAL**  
 Before operating finishing equipment, read and understand all safety, operation and maintenance information provided in the operation manual.



**WEAR SAFETY GLASSES**  
 Failure to wear safety glasses with side shields could result in serious eye injury or blindness.



**DE-ENERGIZE, DEPRESSURIZE, DISCONNECT AND LOCK OUT ALL POWER SOURCES DURING MAINTENANCE**  
 Failure to De-energize, disconnect and lock out all power supplies before performing equipment maintenance could cause serious injury or death.



**OPERATOR TRAINING**  
 All personnel must be trained before operating finishing equipment.



**EQUIPMENT MISUSE HAZARD**  
 Equipment misuse can cause the equipment to rupture, malfunction, or start unexpectedly and result in serious injury.

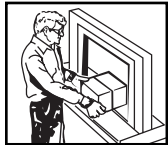

**KEEP EQUIPMENT GUARDS IN PLACE**  
 Do not operate the equipment if the safety devices have been removed.

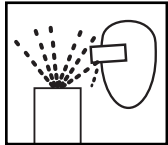

**PROJECTILE HAZARD**  
 You may be injured by venting liquids or gases that are released under pressure, or flying debris.



**PINCH POINT HAZARD**  
 Moving parts can crush and cut. Pinch points are basically any areas where there are moving parts.



**AUTOMATIC EQUIPMENT**  
 Automatic equipment may start suddenly without warning.



**INSPECT THE EQUIPMENT DAILY**  
 Inspect the equipment for worn or broken parts on a daily basis. Do not operate the equipment if you are uncertain about its condition.



**NEVER MODIFY THE EQUIPMENT**  
 Do not modify the equipment unless the manufacturer provides written approval.



**KNOW WHERE AND HOW TO SHUT OFF THE EQUIPMENT IN CASE OF AN EMERGENCY**



**PRESSURE RELIEF PROCEDURE**  
 Always follow the pressure relief procedure in the equipment instruction manual.



**NOISE HAZARD**  
 You may be injured by loud noise. Hearing protection may be required when using this equipment.



**STATIC CHARGE**  
 Fluid may develop a static charge that must be dissipated through proper grounding of the equipment, objects to be sprayed and all other electrically conductive objects in the dispensing area. Improper grounding or sparks can cause a hazardous condition and result in fire, explosion or electric shock and other serious injury.



**FIRE AND EXPLOSION HAZARD**  
 Never use 1,1,1-trichloroethane, methylene chloride, other halogenated hydrocarbon solvents or fluids containing such solvents in equipment with aluminum wetted parts. Such use could result in a serious chemical reaction, with the possibility of explosion. Consult your fluid suppliers to ensure that the fluids being used are compatible with aluminum parts.



**TOXIC FLUID & FUMES**  
 Hazardous fluid or toxic fumes can cause serious injury or death if splashed in the eyes or on the skin, inhaled, injected or swallowed. LEARN and KNOW the specific hazards of the fluids you are using.



**WEAR RESPIRATOR**  
 Toxic fumes can cause serious injury or death if inhaled. Wear a respirator as recommended by the fluid and solvent manufacturer's Material Safety Data Sheet.

**FOR FURTHER SAFETY INFORMATION REGARDING BINKS AND DEVILBISS EQUIPMENT, SEE THE GENERAL EQUIPMENT SAFETY BOOKLET (77-5300).**

## OPERATION and MAINTENANCE INSTRUCTIONS for M1-G HVLP SPRAY GUN

Your new M1-G HVLP Spray Gun is exceptionally rugged in construction and is built to stand up under hard, continuous use. However, like any other fine precision instrument, its most efficient operation depends on a knowledge of its construction, operation and maintenance. Properly handled and cared for, it will produce beautiful, uniform finishing results long after other spray guns have worn out.

**IMPORTANT:** Before removing any components from the spray gun, shut off air pressure and drain material from the paint cup.

### SETUP FOR SPRAYING

#### CONNECTING GUN TO AIR HOSE

Air should be supplied by a suitable length of 5/16" diameter air hose fitted with a 1/4 NPS(f) connection at gun end. For hose lengths over 50', use 3/8" hose.

#### CONNECTING GRAVITY FEED CUP TO GUN

(Figure 1) Screw the cup into the spray gun fluid inlet.

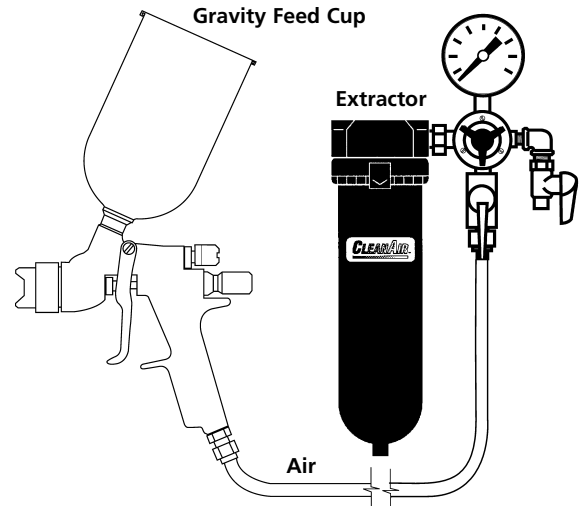

Fig. 1

## OPERATING THE M1-G HVLP SPRAY GUN

### NOTE

All numbers in parentheses ( ) refer to item numbers in Assembly Drawing on Page 6.

#### CONTROLLING THE MATERIAL FLOW

Correct fluid nozzle size should be selected for proper material flow rate. The material valve control knob (19) may be used to restrict the material needle valve opening and reduce the material flow as necessary.

#### CONTROLLING THE FAN SPRAY

The fan spray is controlled by means of the side port control assembly (9). Turning this control clockwise until it is closed will give a round spray. Turning it counter-clockwise will widen the spray into a fan shape. The fan spray can be turned anywhere through 360° by positioning the air cap (2) relative to the gun. To affect this, loosen retainer ring, position nozzle, then tighten retainer ring.

## TROUBLE SHOOTING

#### FAULTY SPRAY

A faulty spray is often caused by improper cleaning, resulting in dried materials around the material nozzle tip or in the air nozzle. Soak these parts in thinners to soften the dried material and remove with brush or cloth.

### CAUTION

Never use metal instruments to clean the air or material nozzles. These parts are carefully machined and any damage to them will cause faulty spray.

If either the air cap (2) or fluid nozzle (3) are damaged, these parts must be replaced before perfect spray can be obtained.

#### INTERMITTENT SPRAY

Fluttering spray is caused by either insufficient material in the gravity feed cup or a clogged fluid passage. If the fluid passage is clogged, drain material from the paint cup and remove the cup and fluid nozzle. Clean the fluid passage with solvent and reassemble.

## SPRAY GUN CLEANING INSTRUCTIONS

In certain states, spraying solvents which contain Volatile Organic Compounds (VOC) into the atmosphere when cleaning a spray gun is now prohibited.

In order to comply with these new air quality laws Binks recommends one of the following two methods to clean your spray finishing equipment:

1. Spray solvent through the gun into a *closed system*. An enclosed unit or spray gun cleaning station condenses solvent vapors back into liquid form which prevents escape of VOC's into the atmosphere.
2. Place spray gun in a washer type cleaner. This system must totally enclose the spray gun, cups, nozzles and other parts during washing, rinsing and draining cycles. This type of unit must be able to

flush solvent through the gun without releasing any VOC vapors into the atmosphere.

Additionally, open containers for storage or disposal of solvent or solvent-containing cloth or paper used for surface preparation and clean-up may not be used. Containers shall be nonabsorbent.

#### CLEANING GUN AND GRAVITY FEED CUP

Remove the cup cover and drain unused material from cup. Carefully rinse cup with solvent. Place clean solvent into the cup and spray this through the gun until it is clean. Remove and clean the cup if necessary. Blow air through the gun to dry it. (Refer to Service Bulletin SBBI-4-043 for cleaning instructions when using cup liners.)

## MAINTENANCE

### TO REPLACE AIR VALVE AND SPINDLE ASSEMBLY

Remove material control knob (19), spring (16) and fluid needle (18). Unscrew housing (17) and remove spindle assembly (15) with springs (14 & 16), seal retainers (13) and o-rings (12). Lubricate new o-rings with Gunner's Mate. Assemble components using material needle. Place this assembly along with housing (17) into gun body and screw into position. Remove material needle and tighten housing.

### TO REPLACE CARTRIDGE ASSEMBLY

Remove material valve control knob (19), spring (16) and remove fluid needle (18). Pull back trigger (21) and remove seal cartridge assembly (22). Remove and discard plastic packing pin in new cartridge assembly. Pull back trigger and insert new seal cartridge assembly. Reassemble fluid needle (18), spring (16) and material valve control knob (19).

## FLUID NOZZLES

### Standard Fluid Nozzles

MATERIAL	FLUID NOZZLE NO.	AIR NOZZLE**	FLUID NEEDLE
LIGHT: 15 to 20 seconds in a ZAHN 2 Cup, e.g., stains, varnishes, thin lacquers, automotive refinishing materials.	92 (.046" Dia.) 1.2 mm 92GS (.046" Dia.) 1.2 mm▲ 93 (.051" Dia.) 1.3 mm● 94 (.055" Dia.) 1.4 mm 94GS (.055" Dia.) 1.4 mm▲	92P●, 93P■, 94P●, 95P●, 95AP*●, 97AP*●, 90P, 96G▲	54-4382  54-4547▲ (See Note)*
MEDIUM: 20 to 60 seconds in a ZAHN 2 Cup, e.g., general industrial coatings	96GS (.063" Dia.) 1.6 mm▲ 97 (.070" Dia.) 1.7 mm 903 (.079" Dia.) 2.0 mm●	905P	54-4382
HEAVY: greater than 60 seconds in a Zahn 2 Cup.	905 (.089" Dia.) 2.3 mm 906 (.100" Dia.) 2.5 mm● 909 (.111" Dia.) 2.8 mm●		

\*\* The 97P or 907P Air Nozzles may be used, but will cause a significant reduction in fluid flow rate.

■ Optimum setup for fine automotive spray is 94 x 93P.

\* "BLUE MAX" fine finish nozzles. (Retaining ring attached).

● Optional.

▲ Recommended Fluid and Air Nozzle combinations for clear coat application.

### NOTE\*

Use stainless steel fluid needle (54-4382) for these nozzles. Optional nylon-tipped stainless steel fluid needle (54-4381) is also available. Use 54-4547 needle with 92GS, 94GS and 96GS fluid nozzles.

## FEATHERING NOZZLES

For applications requiring more gradual Material Valve opening; metering control of fluid flow is obtained with Gun Trigger.

MATERIAL	FLUID NOZZLE NO.	APPLICABLE AIR NOZZLES**	FLUID NEEDLE
LIGHT/MEDIUM	94F (.055" Dia.) 1.4 mm●	92P●, 93P■, 94P●, 95P●, 95AP*●, 97AP*●	54-4390●
MEDIUM	97F (.070" Dia.) 1.7 mm●		54-4391●
HEAVY	906F (.100" Dia.) 2.5 mm●	905P	54-4394●
	909F (.111" Dia.) 2.8 mm●		54-4395●

### NOTE

This chart applies to M1-G Gravity Feed Guns only.

### LVP AIR NOZZLE 93P

NOZZLE ATOMIZING AIR FLOW (SCFM)	NOZZLE ATOMIZING PRESSURE (PSI)	GUN INLET PRESSURE (PSI)	REGULATOR PRESSURE (PSI)
5.5	3.0	8.0	10.0
7.0	5.0	11.5	14.0
8.0	7.0	14.5	18.0
9.5	9.0	17.0	22.5
10.0	10.0	18.0	24.0

### HVLP AIR NOZZLE 96G

NOZZLE ATOMIZING AIR FLOW (SCFM)	NOZZLE ATOMIZING PRESSURE (PSI)	GUN INLET PRESSURE (PSI)	REGULATOR PRESSURE (PSI)
7.5	3.0	23.0	35.0
14.0	5.0	29.0	42.0
15.5	7.0	33.0	47.0
17.5	9.0	39.0	55.0
19.0	10.0	43.0	60.0

### LVP AIR NOZZLES 92P

NOZZLE ATOMIZING AIR FLOW (SCFM)	NOZZLE ATOMIZING PRESSURE (PSI)	GUN INLET PRESSURE (PSI)	REGULATOR PRESSURE (PSI)
4.5	3.0	6.0	9.0
6.0	5.0	8.5	10.0
6.8	7.0	11.5	14.0
7.5	9.0	13.5	18.0
8.0	10.0	15.0	19.0

92P and 93P are for general industrial and automotive finish applications.

### HVLP AIR NOZZLES 95P, 97P, 95AP, 97AP, 905P, 907P

NOZZLE ATOMIZING AIR FLOW (SCFM)	NOZZLE ATOMIZING PRESSURE (PSI)	GUN INLET PRESSURE (PSI)	REGULATOR PRESSURE (PSI)
11.0	3.0	20.0	27.0
15.7	5.0	30.0	40.0
17.5	7.0	38.0	50.0
19.6	9.0	45.0	58.0
22.5	10.0	50.0	64.0

### HVLP AIR NOZZLE 94P

NOZZLE AIR FLOW (SCFM)	NOZZLE ATOMIZING (PSI)	GUN INLET PRESSURE (PSI)
7.0	3.0	14.0
9.0	5.0	21.0
11.0	7.0	27.0
12.0	9.0	30.0
13.0	10.0	33.0

### AIR NOZZLES

#### AIR PRESSURE RECOMMENDATIONS

TYPE OF MATERIAL	ATOMIZING PSI
Light Stains, Inks	3-4
Primer/surfaces	5-6
Acrylic Enamels	7-8
Lacquers	7-8
Low VOC, Urethanes	8-10

#### AIR NOZZLE RECOMMENDATIONS:

The 93P and 905P Air Nozzles are most suitable for conventional materials. Use of very low fluid delivery rates with these Nozzles will produce a narrower than normal fan pattern.

Use the 97P and 907P Air Nozzles for heavy bodied, high solids materials and low fluid flow rates with conventional materials. High flow rates with light bodied materials may result in some minor "smoking" or material build-up on the face of these nozzles.

USE OF THE 95AS OR 97AS SIPHON NOZZLES IS NOT RECOMMENDED WITH THE M1-G GRAVITY FEED GUN.

### NOTE

Regulator pressures are based on 25' of 5/16" Hose in good condition without Quick-Disconnects or other restrictive fittings. Use the Air Nozzle Test Gauge accessory to confirm the atomizing/regulator pressure relationship for your actual air supply set-up. These recommendations are for "typical" or "average" materials, and are intended to serve as a starting point. Adjust as necessary for your specific application.

ASSEMBLY DRAWING FOR THE M1-G GRAVITY FEED SPRAY GUN

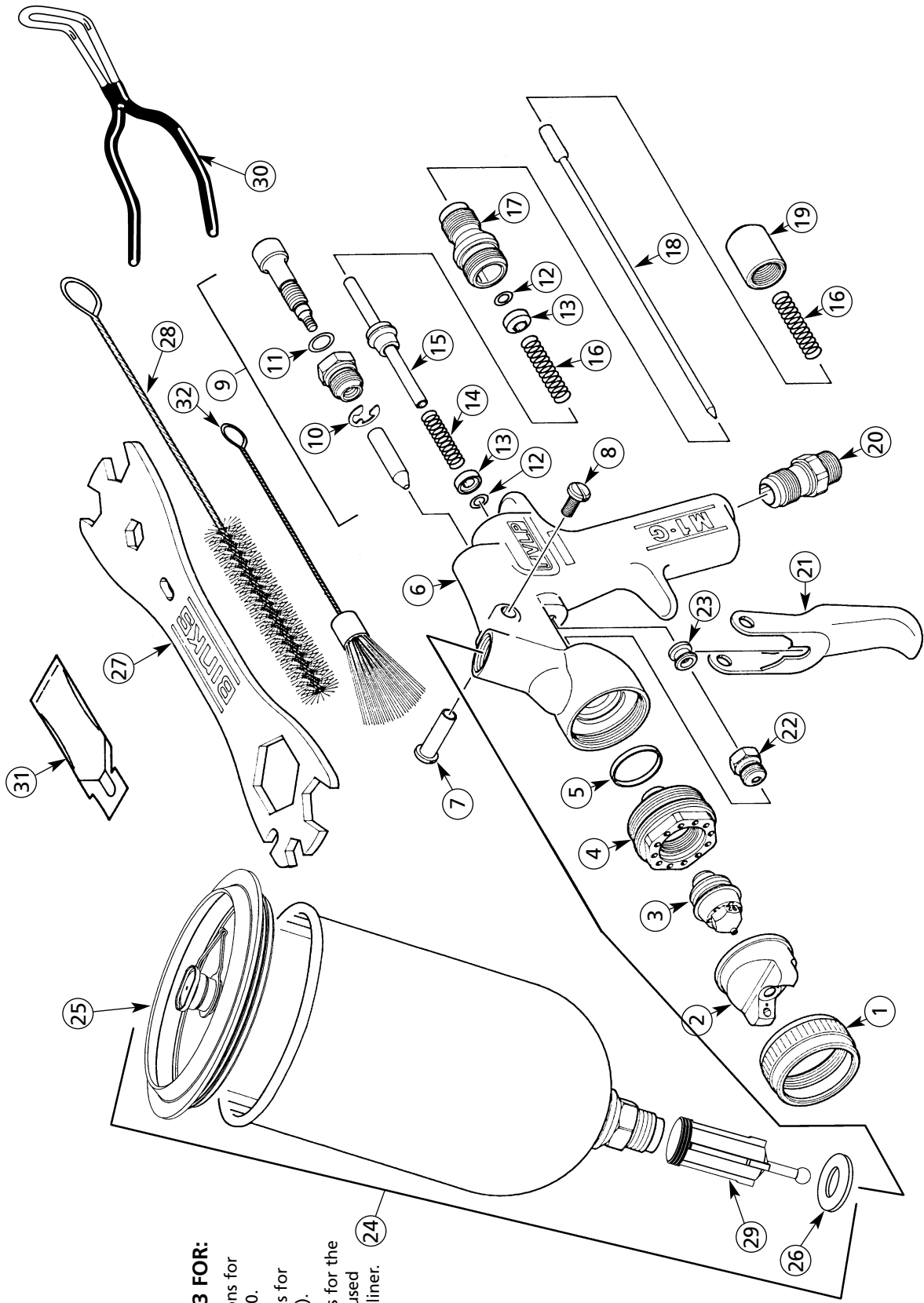

**REFER TO SERVICE BULLETIN SBBI-4-043 FOR:**

- Warnings and cautions for cup assembly 54-4720.
- Assembly instructions for the liner (not shown).
- Cleaning instructions for the cup assembly when used with or without the liner.

## PARTS LIST

(When ordering, please specify PART NO.)

ITEM NO.	PART NO.	DESCRIPTION	QTY.
1	54-3531	RETAINING RING .....	1
2	★	AIR CAP .....	1
3	★	FLUID NOZZLE .....	1
4	54-4368	HEAD INSERT .....	1
5	54-4369-5▲○	HEAD INSERT SEAL RING .....	1
6	54-4361▼	M1-G HANDLE ASSEMBLY	
7	54-4359	TRIGGER STUD .....	1
8	82-126	TRIGGER SCREW .....	1
9	54-4364●	SIDE PORT CONTROL ASSEMBLY .....	1
10	54-3511▲	RETAINING RING .....	1
11	20-6160▲	O-RING .....	1
12	20-4615-5▲○	O-RING .....	2
13	54-3515	SEAL RETAINER .....	2
14	54-3520▲	SPRING (Yellow) .....	1
15	54-3512▲	SPINDLE ASSEMBLY .....	1
16	54-3518▲	SPRING (Blue) .....	2
17	54-3541	HOUSING .....	1
18	★	FLUID NEEDLE .....	1
19	54-3606	MATERIAL VALVE CONTROL KNOB .....	1
20	54-768	AIR CONNECTION	
21	54-4360	TRIGGER .....	1
22	54-4370▲	SEAL CARTRIDGE ASSEMBLY .....	1
23	54-3513	VALVE SPINDLE CAP .....	1
24	54-4720	1 LITER GRAVITY FEED CUP ASSEMBLY .....	1
25	GFC-404□	DISPOSABLE LID ASSEMBLY (Quantity 2 supplied / 54-4720)	
26	KGP-13▲+	CUP GASKET (Blue).....	1
27	54-3918■	WRENCH (Optional) .....	1
28	82-469	GUN BRUSH (Round) .....	1
29	KGP-5*	FILTER .....	
30	192219	PLASTIC COATED GUN HOOK.....	1
31	54-3871◆	GUNNER'S MATE .....	1
32	82-221	CLEANING BRUSH (Flat) .....	1
33	OMX-70✱	DISPOSABLE LINER (Not Shown) (Refer to Service Bulletin SBBI-4-043)	

- ★ See Air and Fluid Nozzle Chart on Page 4.
- **Optional:** Side Port Control Assembly 54-4365 (QCSP).
- \* Available in 54-4716 Filter Kit (quantity of 5) only.
- ▲ Available in Spare Parts Kit 54-4367.
- Not furnished. Please order separately.
- ▼ Item NOT available separately.
- ◆ Available from Industrial Finishing distributors only.
- Available only as a Quantity Pak.
- Available in 54-4715 Disposable Lid Kit (quantity of 2) only.
- ✱ Available in 54-4717 Cup Gasket (Blue) Kit (quantity of 5) only.
- ✱ Available in OMX-70-K48 Disposable Liner Kit (quantity of 48) only.

## GENERAL SPRAY INSTRUCTIONS

To reduce overspray and obtain maximum efficiency, always spray with the lowest possible fluid/air pressure that produces an acceptable spray pattern.

Excessive atomizing air pressures can increase overspray, reduce transfer efficiency, and with some materials, result in poor finish quality from dry spray. Atomizing air pres-

ures should not exceed 10 psi. See table on page 5, diagram on this page and Regulatory Note on page 9. Generally use 30 - 35 psi at gun inlet (see below). Unusually heavy, difficult to atomize materials may require up to 50 psi air at gun head.

## SPRAY TECHNIQUE

The first requirement for a good resultant finish is the proper handling of the gun. The gun should be held perpendicular to the surface being covered and moved parallel with it. The stroke should be started before the trigger is pulled, and the trigger should be released before the stroke is ended. This gives accurate control of the gun and material.

The distance between gun and surface should be 6 to 10 inches depending on material and atomizing pressure. The material deposited should always be even and wet. Lap each stroke over the preceding stroke to obtain a uniform finish.

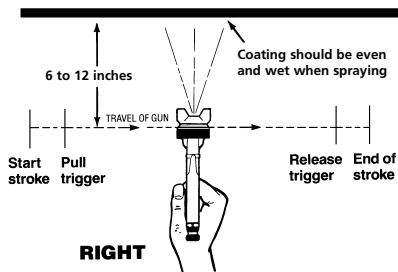

**RIGHT**

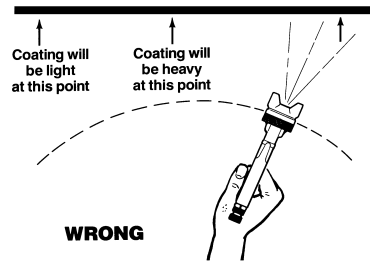

**WRONG**

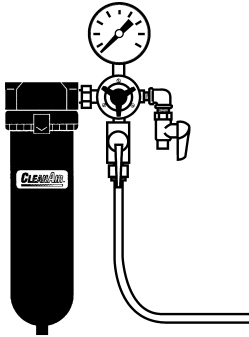

### Oil and Water Extractor is important

Achieving a fine spray finish without the use of a good oil and water extractor is virtually impossible.

A Regulator/Extractor serves a double purpose. It eliminates blistering and spotting by keeping air free of oil and water and it gives precise air pressure control at the gun. See page 3 regarding installation of extractors.

Atomizing pressure must be set to allow for the drop in air pressure between the regulator and the spray gun.

## HOSE RECOMMENDATION

With 60 psi applied at air supply:

Approx.  
5 1/2 psi  
at Nozzle

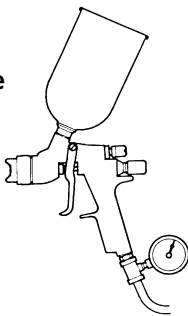

Only 34 psi  
at Gun Inlet

25 feet of  
1/4" I.D. hose  
causes a drop  
of 26 psi  
between the  
air supply  
and the gun.

1/4"



**NOT RECOMMENDED**

Approx.  
9 psi  
at Nozzle

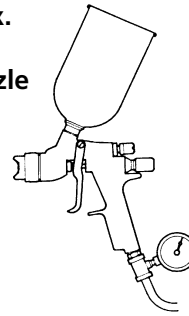

48 psi  
at Gun Inlet

25 feet of 5/16" I.D.  
hose causes a drop  
of 12 psi between  
the air supply and  
the gun. For this  
reason we recommend  
the use of 5/16" hose.

5/16"



**RECOMMENDED**

Cross section view showing comparison of inside hose diameters (actual size). 60 lbs regulated pressure.



### IMPORTANT REGULATORY NOTE

Some Regulatory Agencies prohibit the operation of HVLP spray guns above 10 psi nozzle atomizing pressure. Users subject to this type of regulation should not exceed the gun inlet pressure indicated on the air cap. See *General Spray Instructions* and *Air Pressure Recommendations*, page 8. It is recommended that the nozzle test gauge (see below) be used to confirm actual nozzle operating pressure.

It may also be a requirement of some regulatory agencies that users have this gauge nozzle available on site to verify that the gun is being operated within the limits of applicable rules.

### AIR NOZZLE TEST GAUGE ASSEMBLY

54-3935 for 95P, 97P, 95AP, and 97AP Nozzles.

54-3908♦ for 900 Series Nozzles.

54-4345♦ for 90P Air Nozzle.

54-4356 for 93P Air Nozzle.

54-3902♦ for 92P Air Nozzle.

54-4066♦ for 94P Air Nozzle.

54-4566 for 96G Air Nozzle.

♦Available from Industrial Distributors only.

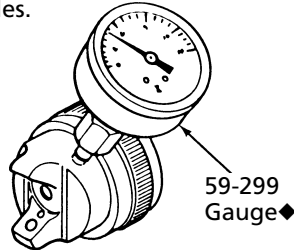

### ACCESSORIES

(When ordering, please specify PART NO.)

Part No.	Description
54-4350	Gun Stand
54-4352	Gun Bracket
192219	Plastic Coated Gun Hook
81-82	Strainer 145 Mesh—typical for Lacquers
81-83	Strainer 100 Mesh—typical for Metal Flake
81-84	Strainer 80 Mesh—typical for Primers

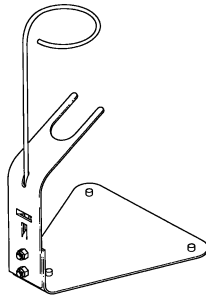

54-4350  
Gun Stand  
(Optional)

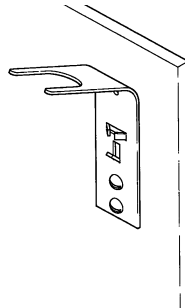

54-4352  
Gun Bracket  
(Optional)

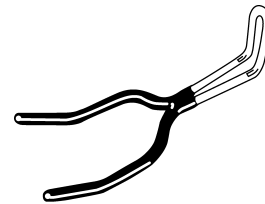

192219  
Plastic Coated Gun Hook  
(Supplied with outfit)

NOTES

NOTES

---

## WARRANTY

This product is covered by Binks' 1 Year Limited Warranty.

---

## Binks Worldwide Sales and Service Listing: [www.binks.com](http://www.binks.com)

---

### Industrial Finishing

Binks has authorized distributors throughout the world. For technical assistance or the distributor nearest you, see listing below.

#### U.S./Canada Technical Service Office:

195 Internationale Blvd., Glendale Heights, IL 60139  
Toll-Free Telephone: 1-888-992-4657 (U.S.A. and Canada only)  
Toll-Free Fax: 1-888-246-5732

**77-2650R-7 Revisions:** (P1) Deleted reference air nozzle availability; (P4) Added Fluid Needle 54-4382 reference to chart.



An Illinois Tool Works Company

9/07 © 2007

Inc. All rights reserved. Printed in U.S.A.