



Ink Manufacturing and Printing Solutions

Solutions for pail, drum, or bulk tank ink applications



PROVEN QUALITY. LEADING TECHNOLOGY.

Leading The Way In Quality Ink Applications

THE INDUSTRY'S MOST RELIABLE PUMPS!

Graco is proud to offer the ink industry a complete line of Priming Piston and Diaphragm pumps. They offer a proven reliable design used by ink manufacturers and printers worldwide. Whether you are pumping high or low viscosity fluids from mixing tanks, bins, drums or pails, Graco has the perfect pumping solution!

Features

- Priming piston pumps have flow rates up to 7.5 gpm (28.3 lpm) and are perfect for high viscosity finished ink or ingredient supply
- Priming piston pumps are available with hydraulic or pneumatic motors
- Husky™ diaphragm pumps have maximum flow rates of 7-275 gpm (26.5-1,041 lpm), and are ideal for low viscosity finished ink supply or high volume ink transfer
- Evacuation from virtually any supply source including bins, drums, pails, dispersion mixers and milling equipment

Applications

- Supplying ink to press fountains
- Supplying raw ink
- Evacuating to dispersion tanks
- Supplying ink to milling equipment
- Supplying ink to batch dispensing systems
- Waste water treatment
- Pumping solvents for ink wash systems

Key Industries

- Letterpress and lithographic ink manufacturing
- Flexographic and gravure ink manufacturing
- Magazine and commercial printers
- Newspaper printers



A COMPLETE LINE OF PUMPS AND POWER SOURCES

Whether your specialty is ink manufacturing, printing, or both, it's tough to beat these Graco pumps!

Graco offers a variety of priming piston and diaphragm pumps, for low to high viscosity inks, that are built for years of reliable service. A wide range of pump lowers, motors and mounting configurations guarantee you get the best pump for your application.

Our qualified industrial distributors can expertly combine equipment components and accessories tailored to fit any setup.

Husky Air-Operated Double Diaphragm Pumps

- Ideal for flexographic and gravure ink
- High volume transfer, supply of mixing ingredients and ink packaging
- Unloading dispersion mixers, supplying milling equipment and batch metering of ingredients
- No exposed seal to wear or leak
- Handles low to medium viscosity fluids with ease



Priming Piston Pumps

- Ideal for printing with letterpress or lithographic inks, and ingredient supply in ink manufacturing
- Available with hydraulic or pneumatic motors
- Improved seal design reduces leakage
- Handles high viscosity fluids with ease
- Mounts on powerful pneumatic rams, carts or floor stands
- Compatible with UV inks



Hydraulic or Pneumatic?

Graco offers both hydraulic and pneumatic motors to drive your priming piston pump. Both are top quality choices for smooth, continuous ink delivery.

Pneumatic Motors

Graco's King®, Bulldog®, Senator® and President® pneumatic motors provide rugged, reliable service life for ink manufacturing and printing applications.



King Pneumatic Motor

ALREADY OWN A PNEUMATIC MOTOR?

No problem! Take advantage of significant savings by converting your existing pump to a Graco hydraulic system. See your Graco Distributor for details.

Hydraulic Motors

When paired with any of Graco's priming piston pumps, the Viscount® II hydraulic motor offers exceptional cost savings by operating on 20% of the energy used by pneumatic motors.



Viscount II Hydraulic Motor

Diaphragm Pumps For Ink Supply And Transfer

SUPPLY OR TRANSFER WITH EASE!



Husky Air-Operated Double Diaphragm

pumps are ideal for bulk transfer of your solvent or water-based, low to medium viscosity inks and ingredients. They offer easy maintenance with an extremely reliable patented air valve for true non-sticking operation.

Features

- Sizes range from 3/8 in (9.52 mm) to 3 in (76.2 mm)
- Flow rates from 7 - 275 gpm (26.5 - 1,041 lpm)
- Polypropylene, acetal, aluminum and stainless steel materials of construction
- Patented dual cup air valve design resists icing, sticking, and requires no external lubrication
- Fewer moving parts means increased durability
- 3/8 in and 1/2 in sizes are available with single or dual inlet/outlet configurations
- All pumps have a 5-year warranty on the fluid section and a 15 year warranty on the center section

Diaphragm Pump Designation

Part numbers are located on ID tag on center section of all Husky diaphragm pumps.

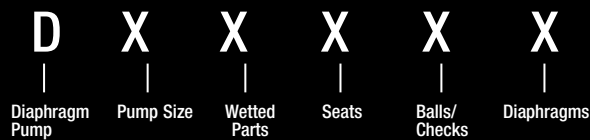

PUMP SIZE (AIR MOTOR TYPE AND MATERIAL)	WETTED PARTS	SEATS	BALLS	DIAPHRAGM
3 = 3/8" (9.52 mm) Standard: polypropylene center section	1 = Acetal (npt)	2 = Acetal	1 = PTFE	1 = PTFE
5 = 1/2" (12.7 mm) Standard: polypropylene center section	2 = Poly (npt)	3 = Stainless Steel	2 = Acetal	5 = TPE
4 = 1/2" (12.7 mm) Remote: polypropylene center section	3 = Aluminum (npt)	4 = Hardened SST	3 = Stainless Steel	6 = Santoprene
5 = 3/4" (19.05 mm) Standard: polypropylene center section	4 = Stainless Steel (npt)	5 = TPE	4 = Hardened SST	7 = Buna N
4 = 3/4" (19.05 mm) Remote: polypropylene center section	5 = PVDF (npt)	6 = Santoprene	5 = TPE	8 = FKM
7 = 1" (25.4 mm) Standard: aluminum center section	6 = Ductile Iron (npt)	7 = Buna N	6 = Santoprene	G = Geolast
8 = 1" (25.4 mm) Remote: aluminum center section		8 = FKM	7 = Buna N	
R = 1" (25.4 mm) Standard: stainless steel center section	A = Acetal * (bsp)	9 = Polypropylene	8 = FKM	
B = 1-1/2" (38.1 mm) Standard: aluminum center section	B = Poly * (bsp)	A = PVDF	9 = Polypropylene	
C = 1-1/2" (38.1 mm) Remote: aluminum center section	C = Aluminum (bsp)	G = Geolast	A = PVDF	
T = 1-1/2" (38.1 mm) Standard: stainless steel center section	D = Stainless Steel (bsp)		G = Geolast	
F = 2" (50.8 mm) Standard: aluminum center section	E = PVDF (bsp)	B = SST with viton seal		
G = 2" (50.8 mm) Remote: aluminum center section	F = Ductile Iron (bsp)	C = Santoprene with viton seal		
V = 2" (50.8 mm) Standard: stainless steel center section				
K = 3" (76.2 mm) Standard: aluminum center section	H = 2 npt Alum Extended			
	G = 2 bsp Alum Extended			

* = BSP plastic in 1/2" (12.7mm) pumps
 ≥1" Plastic pumps flange connections
 3" Aluminum pumps flange connections

HUSKY

WE'VE GOT THE SOLUTION!

Proven reliability across many industries, Husky Air-Operated Double Diaphragm pumps expertly supply and transfer fluids in both ink printing and manufacturing. With seven sizes and four materials of construction, Graco has a pumping solution perfect for your application!

Graco's large ported, high volume diaphragm pumps efficiently evacuate dispersion tanks, or supply material to milling equipment in ink manufacturing. Smaller, more portable Husky designs are better suited for batch dispensing high volume, low viscosity materials.

Supplying flexographic or gravure inks to printing fountains requires small, more portable Husky pumps that circulate the ink at a desired flow. Choose a pump with a dual inlet/outlet for added flexibility.

PRINTING

FLEXOGRAPHIC AND GRAVURE INKS

	Up to 7 gpm (26 lpm) 58 lb/min* (29 kg/min)	Up to 15 gpm (56 lpm) 125 lb/min* (56 kg/min)	Up to 40 gpm (151 lpm) 333 lb/min* (151 kg/min)	Up to 75 gpm (283 lpm) 625 lb/min* (283 kg/min)
60-80 cps	Husky 307**	Husky 515** Husky 716	Husky 1040	Husky 1590 Husky 2150 Husky 3275

*Assumes specific gravity of 1.0

** Indicates an available dual inlet/outlet configuration

MANUFACTURING

LITHOGRAPHIC AND LETTERPRESS INKS

	Up to 7 gpm (26 lpm) 64 lb/min* (29 kg/min)	Up to 15 gpm (56 lpm) 137 lb/min* (62 kg/min)	Up to 40 gpm (151 lpm) 366 lb/min* (166 kg/min)	Up to 75 gpm (283 lpm) 687 lb/min* (311 kg/min)
5,000 cps	Husky 515 Husky 716 Up to 15 gpm (56 lpm)	Husky 1040	Husky 1590 Husky 2150	Husky 2150 Husky 3275
10,000 cps	Husky 1040	Husky 1590 Husky 2150	Husky 2150 Husky 3275	Husky 3275
20,000 cps	Husky 2150	Husky 2150	Husky 3275	

*Assumes specific gravity of 1.1



Piston Pumps For Letterpress & Lithographic Inks

PUMPING YOUR HIGHEST VOLUMES AND VISCOSITIES!

With higher pump pressures and flow rates, Graco priming piston pumps handle a broad range of inks with ease. They offer durability, power and reliability in any ink manufacturing or printing application.

Ideal for INK Manufacturers & Printers

- Low to high volume multiple press printers using letterpress or lithographic inks
- Ingredient supply to dispersion mixers
- Custom UV ink packages available

Features

- Three priming piston pump sizes – 450 (1.2 gpm), 800 (2.8 gpm) and 2100 (7.5 gpm)
- Maximum pressures of 3100 psi (213 bar) when paired with one of five motors
- Positive displacement, priming piston design provides uniform and easily-controlled delivery
- Extremely durable pump with long-life packing design, and low maintenance
- Evacuates from pails, drums and bins with ease



KING

Produces up to 2400 psi (165 bar) when mounted to a 2100 pump



BULLDOG

Produces up to 1200 psi (82 bar) when mounted to a 800 pump and 3100 psi (231 bar) when mounted to a 2100 pump



SENATOR

Produces up to 1900 psi (130 bar) when mounted to a 800 pump



PRESIDENT

Produces up to 1000 psi (68 bar) when mounted to a 450 pump

CHOOSE THE RIGHT PUMP FOR YOUR APPLICATION

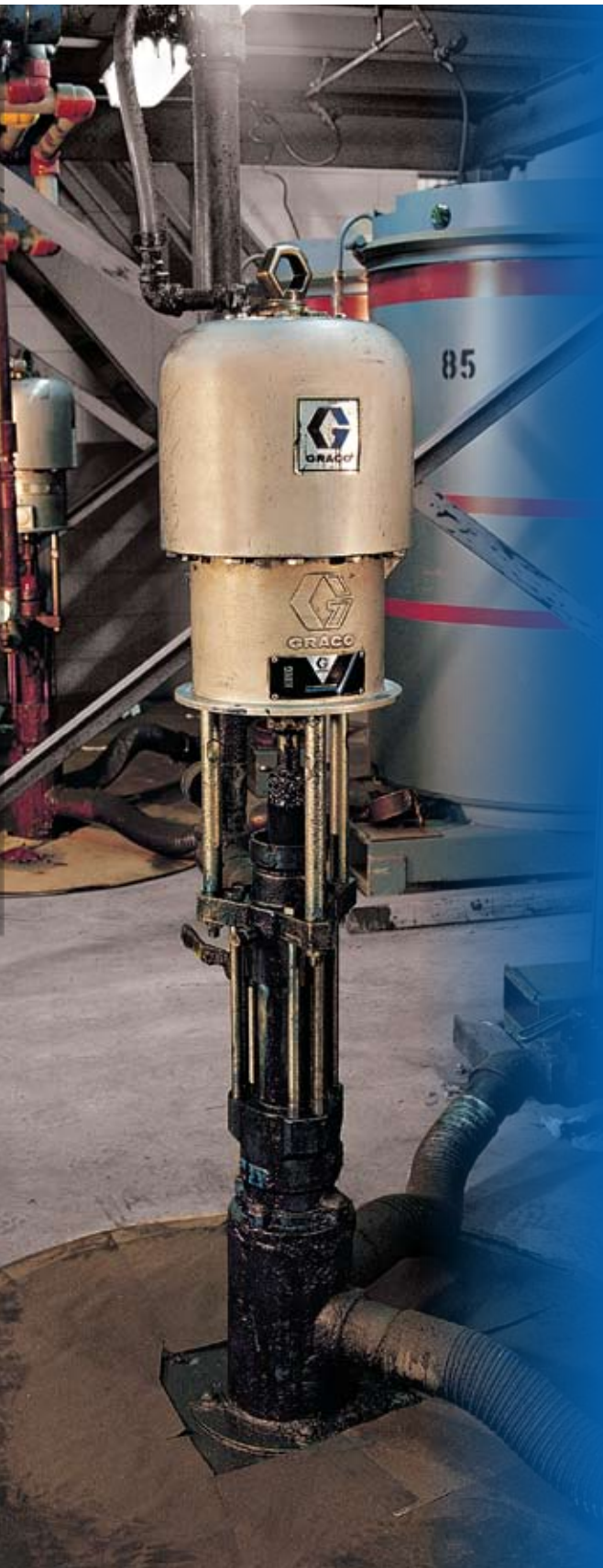

Whether you are supplying ink ingredients to a dispersion mixer or finished inks to your printing press, Graco has a pumping solution!

Choose from our complete selection of pumps and packages for transferring from pails, drums and bins.

PAILS

Up to 1 gpm (3.7 lpm)
9.6 lb/min* (4.3 kg/min)

- 10:1 President

DRUMS

Up to 1 gpm (3.7 lpm)
9.6 lb/min* (4.3 kg/min)

Up to 2.8 gpm (10.5 lpm)
27.5 lb/min* (12.4 kg/min)

Up to 7.5 gpm (28.3 lpm)
73 lb/min* (33.1 kg/min)

- 10:1 President

- 19:1 Senator
- Viscount II 1900
- 31:1 Bulldog
- Viscount II 3100

- 12:1 Bulldog
- Viscount II 1200
- 24:1 King
- Viscount II 2400

BINS

Up to 1 gpm (3.7 lpm)
9.6 lb/min* (4.3 kg/min)

Up to 2.8 gpm (10.5 lpm)
27.5 lb/min* (12.4 kg/min)

Up to 7.5 gpm (28.3 lpm)
73 lb/min* (33.1 kg/min)

- 19:1 Senator
- Viscount II 1900
- 31:1 Bulldog
- Viscount II 3100

- 19:1 Senator
- Viscount II 1900
- 31:1 Bulldog
- Viscount II 3100

- 12:1 Bulldog
- Viscount II 1200
- 24:1 King
- Viscount II 2400



Viscount II Hydraulic Motor

Replaces the King, Bulldog or Senator motors with the 800 or 2100 pump

**Saves up to 80%
on energy!**

Check out the Return-On-Investment Analysis to learn how you can start saving with a Graco Viscount II hydraulic powered system!

Technical Specifications and Ordering Information

Name of Pump	Senator 19:1	Viscount II 1900	Bulldog 31:1	Viscount II 3100
Lower size	800	800	800	800
Maximum fluid pressure	1900 psi (131 bar, 13.1 MPa)	1900 psi (131 bar, 13.1 MPa)	3100 psi (213 bar, 21.3 MPa)	3100 psi (213 bar, 21.3 MPa)
Maximum motor inlet pressure	100 psi (air) (6.9 bar, 0.69 MPa)	450 psi (oil) (31 bar, 3.1 MPa)	100 psi (air) (6.9 bar, 0.69 MPa)	750 psi (oil) (51.7 bar, 5.1 MPa)
Flow rate @ 60 cpm	2.8 gpm (10.6 lpm)	2.8 gpm (10.6 lpm)	2.8 gpm (10.6 lpm)	2.8 gpm (10.6 lpm)
Cfm or gpm required per gallon	24 cfm	4.3 gpm (16.2 lpm)	32 cfm	4.3 gpm (16.2 lpm)
Fluid pump outlet size	1" npt (f)	1" npt (f)	1" npt (f)	1" npt (f)
Motor inlet size	3/4" npt (f)	3/4" npt (f)	3/4" npt (f)	3/4" npt (f)
Weight of pump	160 lb (73 kg)	177 lb (80 kg)	160 lb (73 kg)	177 lb (80 kg)
Instruction manual	308351	308351	308351	308351

Bin Supply	Senator 19:1	Viscount II 1900	Bulldog 31:1	Viscount II 3100
Pump	246941	246938	246940	246938
Air controls: FRL, 1/2"	217072		217072	
Air run away control, 3/4"	224040		224040	
Air speed control, 1/2"(f)	510441		510441	
Floor stand (3" inlet)	222780	222780	222780	222780
Hydraulic controls*		236865		236865
Outlet hydraulic hose connector 1"(m) x 1-1/2"(f), 1500 psi rated		Not included		Not included

55-Gallon Drum Supply	Senator 19:1	Viscount II 1900	Bulldog 31:1	Viscount II 3100
Ram package with pump	234377	234378	234374	234378
Air run away control, 3/4"	224040		224040	
Air speed control, 1/2"	510441		510441	
Hydraulic controls*		236865		236865
Outlet hydraulic hose connector 1"(m) x 1-1/2"(f), 1500 psi rated		Not included		Not included

Misc. Information	Senator 19:1	Viscount II 1900	Bulldog 31:1	Viscount II 3100
Pump lower section	246939	246939	246939	246939
Ram plate replacement seals	165601	165601	165601	165601

*Hydraulic controls include hydraulic flow and pressure control, ball valves, 3 ft supply and return hose



19:1 Senator



19:1 Senator on
55 gallon ram



31:1 Bulldog



Viscount II 3100 on
55 gallon ram

Name of Pump	Bulldog 12:1	Viscount II 1200	King 24:1	Viscount II 2400
Lower size	2100	2100	2100	2100
Maximum fluid pressure	1200 psi (82.8 bar, 8.28 MPa)	1200 psi (82.8 bar, 8.28 MPa)	2400 psi (165 bar, 16.5 MPa)	2400 psi (165 bar, 16.5 MPa)
Maximum motor inlet pressure	100 psi (air) (6.9 bar, 0.69 MPa)	750 psi (oil) (51.7 bar, 5.1 Mpa)	100 psi (air) (6.9 bar, 0.69 MPa)	1500 psi (oil) (103 bar, 10.3 Mpa)
Flow rate @ 60 cpm	7.5 gpm (28.4 lpm)	7.5 gpm (28.4 lpm)	7.5 gpm (28.4 lpm)	7.5 gpm (28.4 lpm)
Cfm or gpm required per gallon	20 cfm	1.6 gpm (6 lpm)	25 cfm	1.6 gpm (6 lpm)
Fluid pump outlet size	1-1/2" npt (m)	1-1/2" npt (m)	1-1/2" npt (m)	1-1/2" npt (m)
Motor inlet size	3/4" npt (f)	3/4" npt (f)	3/4" npt (f)	3/4" npt (f)
Weight of pump	142 lb (65 kg)	196 lb (89 kg)	160 lb (73 kg)	196 lb (89 kg)
Instruction manual	308149	308149	308149	308149

Bin Supply	Bulldog 12:1	Viscount II 1200	King 24:1	Viscount II 2400
Pump	246935	246937	246936	246937
Air controls: FRL, 1/2"	217072		217072	
Air run away control, 3/4"	224040		224040	
Air speed control, 1/2"(f)	510441		510441	
Floor stand (3" inlet)	222780	222780	222780	222780
Hydraulic controls*		236865		236865
Outlet hydraulic hose connector 1"(m) x 1-1/2" (f), 1500 psi rated		Not included		Not included

55-Gallon Drum Supply	Bulldog 12:1	Viscount II 1200	King 24:1	Viscount II 2400
Ram package with pump	234371	234376	234372	234376
Air run away control, 3/4"	224040		224040	
Air speed control, 1/2"(f)	510441		510441	
Hydraulic controls*		236865		236865
Outlet hydraulic hose connector 1"(m) x 1-1/2" (f), 1500 psi rated		Not included		Not included

Misc. Information	Bulldog 12:1	Viscount II 1200	King 24:1	Viscount II 2400
Pump lower section	246934	246934	246934	246934
Ram plate replacement seals	165601	165601	165601	165601

*Hydraulic controls include hydraulic flow and pressure control, ball valves, 3 ft supply and return hose



12:1 Bulldog



Viscount II 2100



24:1 King



Viscount II 2400 on
55 gallon ram

Technical Specifications and Ordering Information

Piston Pumps	President 20:1
Lower size	450
Maximum fluid pressure	2000 psi (140 bar, 14 MPa)
Maximum motor inlet pressure	100 psi (7 bar, 0.7 MPa)
Flow rate @ 60 cpm	1.2 gpm (4.5 lpm)
Cfm or gpm required per gallon	35 cfm
Fluid pump outlet size	3/4" npt (f)
Motor inlet size	1/2" npt (f)
Weight of pump	50 lb (22.7 kg)
Instruction manual	308017

Bin Supply	President 20:1
Pump	246933
Air controls: FRL, 3/8" (f)	110150
Floor stand (3" inlet)	222780
Air run away control, 3/4" (f)	224040
Air speed control 1/2" (f)	510441

55-Gallon Drum Supply	President 20:1
Ram package with pump and air regulator	234369
Air run away control, 3/4" (f)	224040
Air speed control, 1/2" (f)	510441

55-Gallon Pail Supply	President 20:1
Cart package with pump	234370
Air run away control, 3/4" (f)	224040
Air speed control, 1/2" (f)	510441

Misc. Information	President 20:1
Pump lower section	246932
Ram plate replacement seals	165601

Floor Mount
12:1 Bulldog with
2100 pump



Ram Mount
31:1 Bulldog with
800 pump



Cart Mount
10:1 President with
450 pump



BINS

DRUMS

PAILS

Available with hydraulic or pneumatic motors!



Cost Savings That Are Hard To Beat

CHOOSE HYDRAULIC AND SAVE!

Unlike pneumatic, hydraulic motors continually reuse the oil required to cycle the motor, making hydraulic technology the most efficient solution for pumping ink!

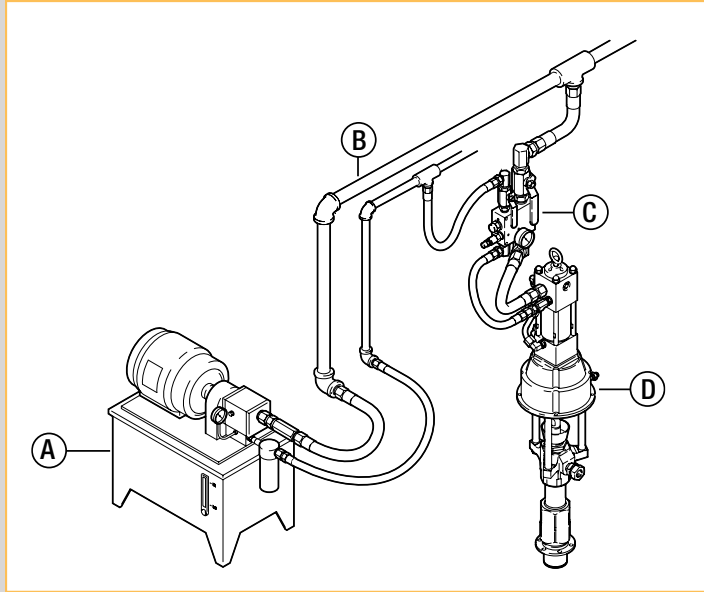

- A. Hydraulic power pack** – Consists mainly of oil reservoir, electric motor and variable volume/pressure-compensated hydraulic pump.
- B. Supply and return lines** – Supplies high pressure oil to the hydraulic ink pump and returns the used oil.
- C. Hydraulic regulator and flow control** – Controls the pressure and flow of oil to the hydraulic motor which, in turn, controls the outlet pressure and cycle rate of the ink pump.
- D. Hydraulic motor** – The Viscount II uses a controlled volume of oil, at a specific pressure, to duplicate the fluid flow and pressures in a pneumatic system. The controlled oil is then circulated back to the power pack for reuse.

Note: Pneumatic motors exhaust the compressed air into the atmosphere after cycling the pump.

Hydraulic Conversion Kit

Convert your pneumatic pump to a Viscount II hydraulic pump today! Just contact your Graco Distributor and ask for part number 15D433.

Return-On-Investment Analysis

PNEUMATIC PUMPS		HYDRAULIC PUMPS	
2000 psi pneumatic pump @ 100 psi inlet air pressure		2000 psi hydraulic pump @ 1300 psi inlet oil pressure	
Number of pumps	4	4	Number of pumps
Total ink pumped per day per pump (gal)	1,200	1,200	Total ink pumped per day per pump (gal)
Total ink used per day	4,800	4,800	Total ink per day
CFM of air per gallon of ink	18 cfm	1.60 gal	Gallon of oil per gallon of ink
Total CFM = CFM/gal x total ink used per day	86,400 cfm	7,680 gal	Total oil = gallons of oil per gallon of ink x total ink used per day
Horsepower (hp) = total cfm ÷ 4	21,600 hp	6,853 hp	Horsepower = (maximum oil pressure x total oil) ÷ (1714 x 0.85)
Daily power consumption (kW/hr) = total hp ÷ 7.46	2,895 kW/hr	919 kW/hr	Daily power consumption (kW/hr) = total hp ÷ 7.46
Energy cost = daily power consumption x kW rate	\$180.97	\$57.41	Energy cost = daily power consumption x kW rate
Daily energy cost savings	\$123.56		
Production days per year	365		
ANNUAL ENERGY SAVINGS USING HYDRAULICS	\$45,096		

Kilowatt rate of \$0.06 is used in calculation



ABOUT GRACO

PROVEN QUALITY. LEADING TECHNOLOGY.

Founded in 1926, Graco is a world leader in fluid handling systems and components. Graco products move, measure, control, dispense and apply a wide range of fluids and viscous materials used in vehicle lubrication, commercial and industrial settings.

The company's success is based on its unwavering commitment to technical excellence, world-class manufacturing and unparalleled customer service. Working closely with qualified distributors, Graco offers systems, products and technology that set the quality standard in a wide range of fluid handling solutions. Graco provides equipment for spray finishing, protective coating, paint circulation, lubrication, and dispensing sealants and adhesives, along with power application equipment for the contractor industry. Graco's ongoing investment in fluid management and control will continue to provide innovative solutions to a diverse global market.

GRACO LOCATIONS

MAILING ADDRESS

P.O. Box 1441
Minneapolis, MN 55440-1441
Tel: 612-623-6000
Fax: 612-623-6777

AMERICAS

MINNESOTA

Worldwide Headquarters
Graco Inc.
88-11th Avenue N.E.
Minneapolis, MN 55413

EUROPE

BELGIUM

European Headquarters
Graco N.V.
Industrieterrein-Oude Bunders
Slakweidestraat 31
3630 Maasmechelen,
Belgium
Tel: 32 89 770 700
Fax: 32 89 770 777

ASIA PACIFIC

AUSTRALIA

Graco Australia Pty Ltd
Suite 17, 2 Enterprise Drive
Bundoora Victoria 3083
Australia
Tel: 61 3 9467 8558
Fax: 61 3 9467 8559

CHINA

Graco Hong Kong Ltd.
Shanghai Representative Office
Room 118 1st Floor
No.2 Xin Yuan Building
No.509 Cao Bao Road
Shanghai, P.R. China 200233
Tel: 86 21 649 50088
Fax: 86 21 649 50077

INDIA

Graco Hong Kong Ltd.
India Liaison Office
Room 432, Augusta Point
Regus Business Centre 53
Gurgaon, Haryana, India 122001
Tel: +91 124 435 4208
Fax: +91 124 435 4001

JAPAN

Graco K.K.
1-27-12 Hayabuchi
Tsuzuki-ku
Yokohama City, Japan 2240025
Tel: 81 45 593 7300
Fax: 81 45 593 7301

KOREA

Graco Korea Inc.
Shinhan Bank Building
4th Floor #1599
Gwanyang-Dong, Dongan-Ku,
Anyang-Si, Gyunggi-Do,
Korea 431-060
Tel: 82(Korea) 31 476 9400
Fax: 82(Korea) 31 476 9801

SALES/ DISTRIBUTION/ SERVICE

Call today for product information or to request a demonstration.

877-84GRACO (1-877-844-7226) or visit us at www.graco.com.

Graco Inc. is registered to I.S. EN ISO 9001

North America
Customer Service
800-328-0211
Fax 877-340-6427